

For Commercial Applications

Job Name _____ Contractor _____
 Job Location _____ Approval _____
 Engineer _____ Contractor's P.O. No. _____
 Approval _____ Representative _____
 Tag _____

BKC-200

16"x32" Kitchen Channel

Specification

BLÜCHER BKC-200 AISI Type 304 stainless steel 16"x32"(400x800) x (specify) deep kitchen channel with 1"(25) thick mesh grating, and bottom outlet.

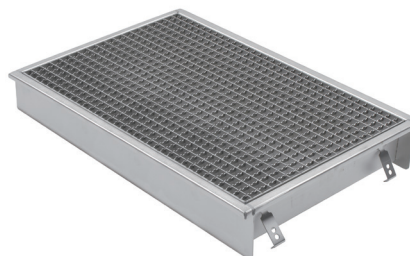

BKC-200

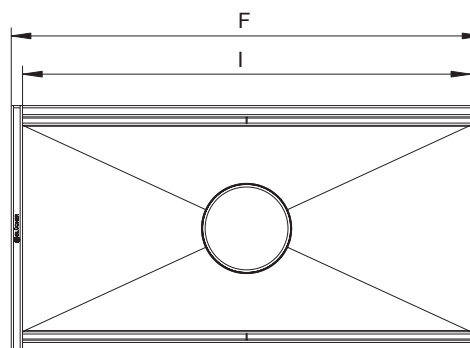
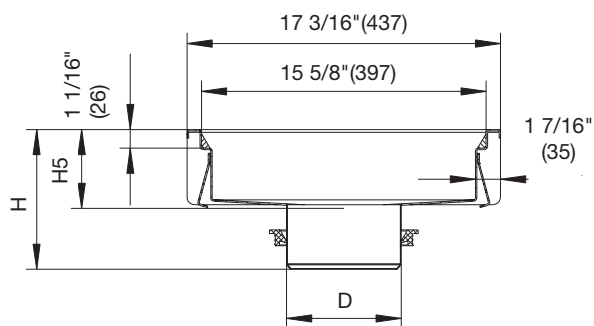

Dimensions

Model No.	Global Part #	Pipe Size		H	Depth	
		D	F		H5	I
BKC-204-2	660FH008-06.22	4"(102)	33"(837)	6 7/16"(163)	2 3/8"(60)	31 3/8"(797)
BKC-204-4	660FH008-11.22	4"(102)	33"(837)	8 3/8"(213)	4 5/16"(110)	31 3/8"(797)
BKC-204-6	660FH008-15.22	4"(102)	33"(837)	10"(253)	5 7/8"(150)	31 3/8"(797)
BKC-206-2	660FK008-06.22	6"(160)	33"(837)	5 11/16"(145)	2 3/8"(60)	31 3/8"(797)
BKC-206-4	660FK008-11.22	6"(160)	33"(837)	7 11/16"(195)	4 5/16"(110)	31 3/8"(797)
BKC-206-6	660FK008-15.22	6"(160)	33"(837)	9 1/4"(235)	5 7/8"(150)	31 3/8"(797)

Options (Select One Or More)		
-316	Type 316 Stainless Steel	<input type="checkbox"/>
-B	Sediment Basket	<input type="checkbox"/>
-E	Edge Infill	<input type="checkbox"/>
-FC	Outlet with Flushing Flange & Clamp	<input type="checkbox"/>
-LD	Grate Locking Device	<input type="checkbox"/>
-P	Stainless Steel P-Trap	<input type="checkbox"/>
-SB	Sand Bucket (6"(160) Outlet Only)	<input type="checkbox"/>

Optional Gratings		
Suffix	Description	<input type="checkbox"/>
-LG	Heavy Duty Ladder Grating	<input type="checkbox"/>

Approvals



Compliance with NSF/ANSI/3-A 14159-1-Hygiene Requirements for the Design of Meat and Poultry Processing Equipment



NOTICE

The information contained herein is not intended to replace the full product installation and safety information available or the experience of a trained product installer. You are required to thoroughly read all installation instructions and product safety information before beginning the installation of this product.



A WATTS Brand

USA: T: (800) 338-2581 • F: (828) 248-3929 • BLUCHERpipe.com
Canada: T: (905) 332-4090 • F: (905) 332-7068 • BLUCHERpipe.com
Latin America: T: (52) 81-1001-8600 • BLUCHERpipe.com
 ES-B-BKC-200 1833